

# AA560V2.2: ROPE AND CHAIN WIRING FOR AA560 SYSTEM

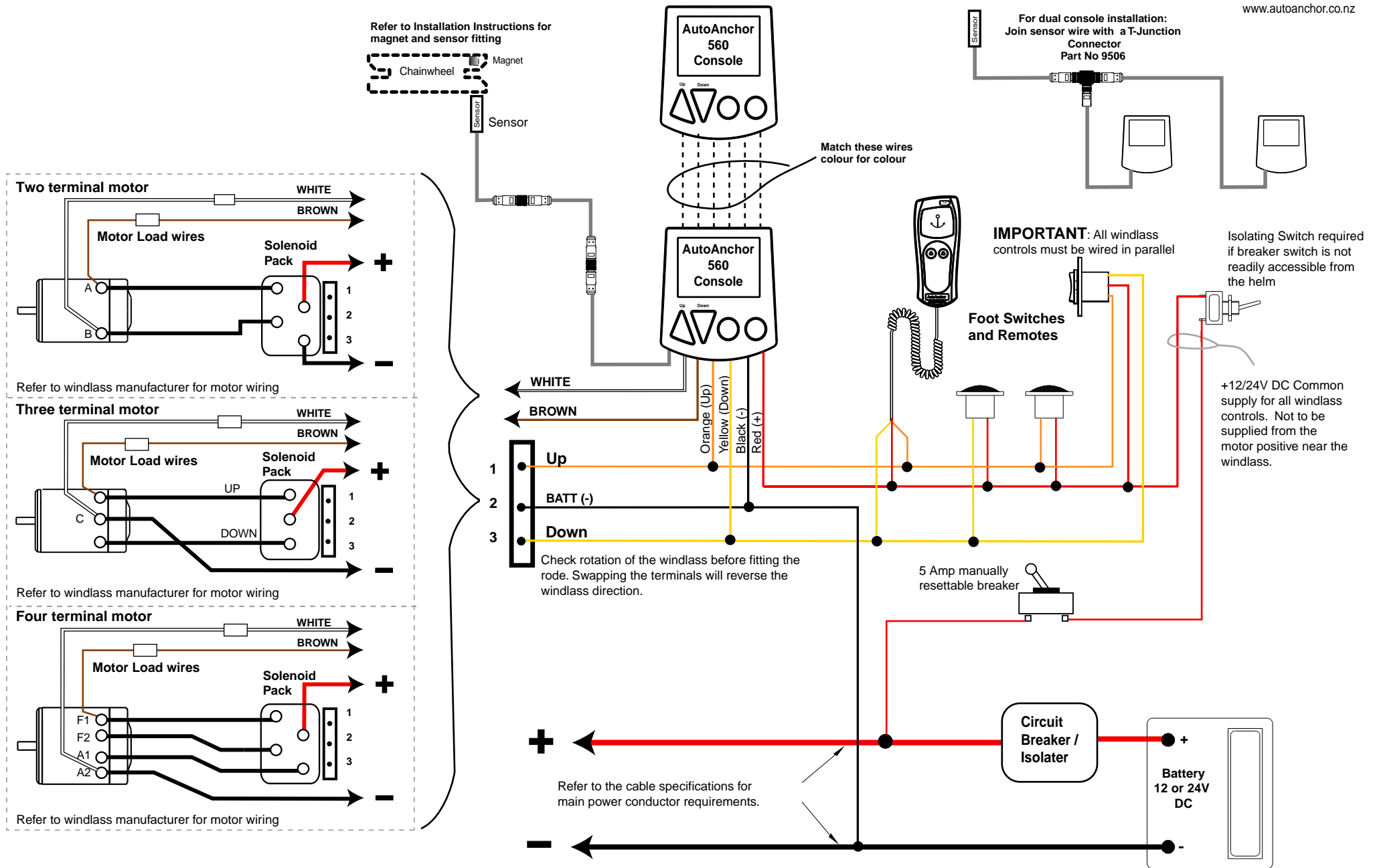

**WARNING:** Power must be disconnected during installation and when making any changes to wiring after installation

INSTALLATIONS MUST BE CARRIED OUT IN ACCORDANCE WITH USCG, ABYC, NMMA and BMEA REQUIREMENTS