

AA560.2: Rope And Chain Wiring for AA560 System

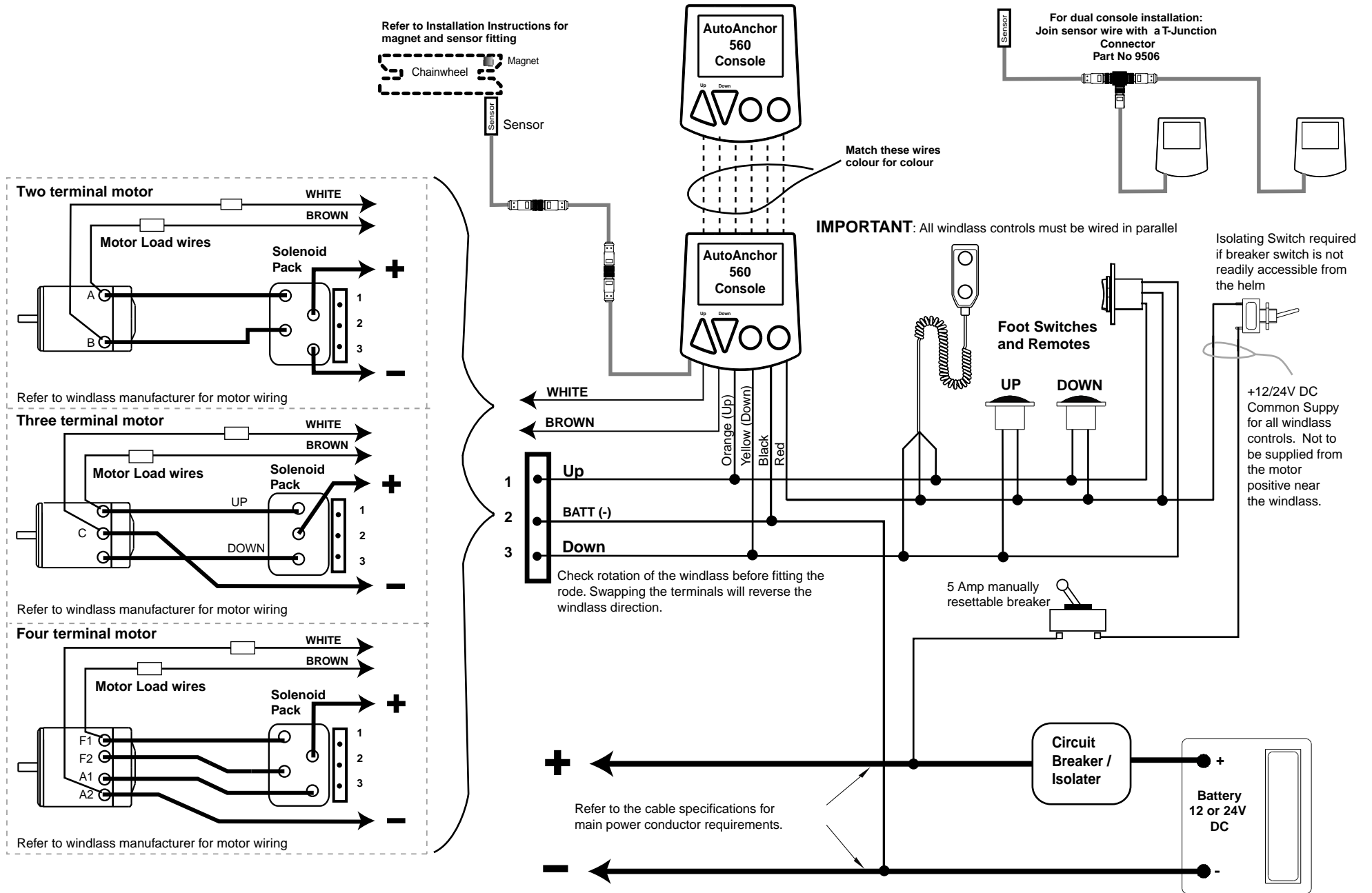

WARNING: Power must be disconnected during installation and when making any changes to wiring after installation

INSTALLATIONS MUST BE CARRIED OUT IN ACCORDANCE WITH USCG, ABYC, NMMA and BMEA REQUIREMENTS

AutoAnchor™ 500 Series
ELECTRONIC WINDLASS CONTROL AND CHAINCOUNTERS