

AA560.1: Chain Only Wiring for AA560 System

Refer to Installation Instructions for magnet and sensor fitting

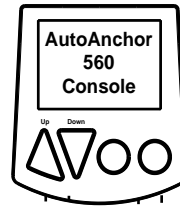
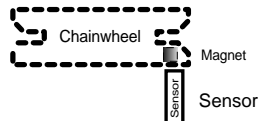

For dual console installation:
Join sensor wire with a T-Junction
Connector
Part No 9506

Match these wires
colour for colour

IMPORTANT: All windlass controls must be wired in parallel

Isolating Switch required
if breaker switch is
not readily accessible
from the helm

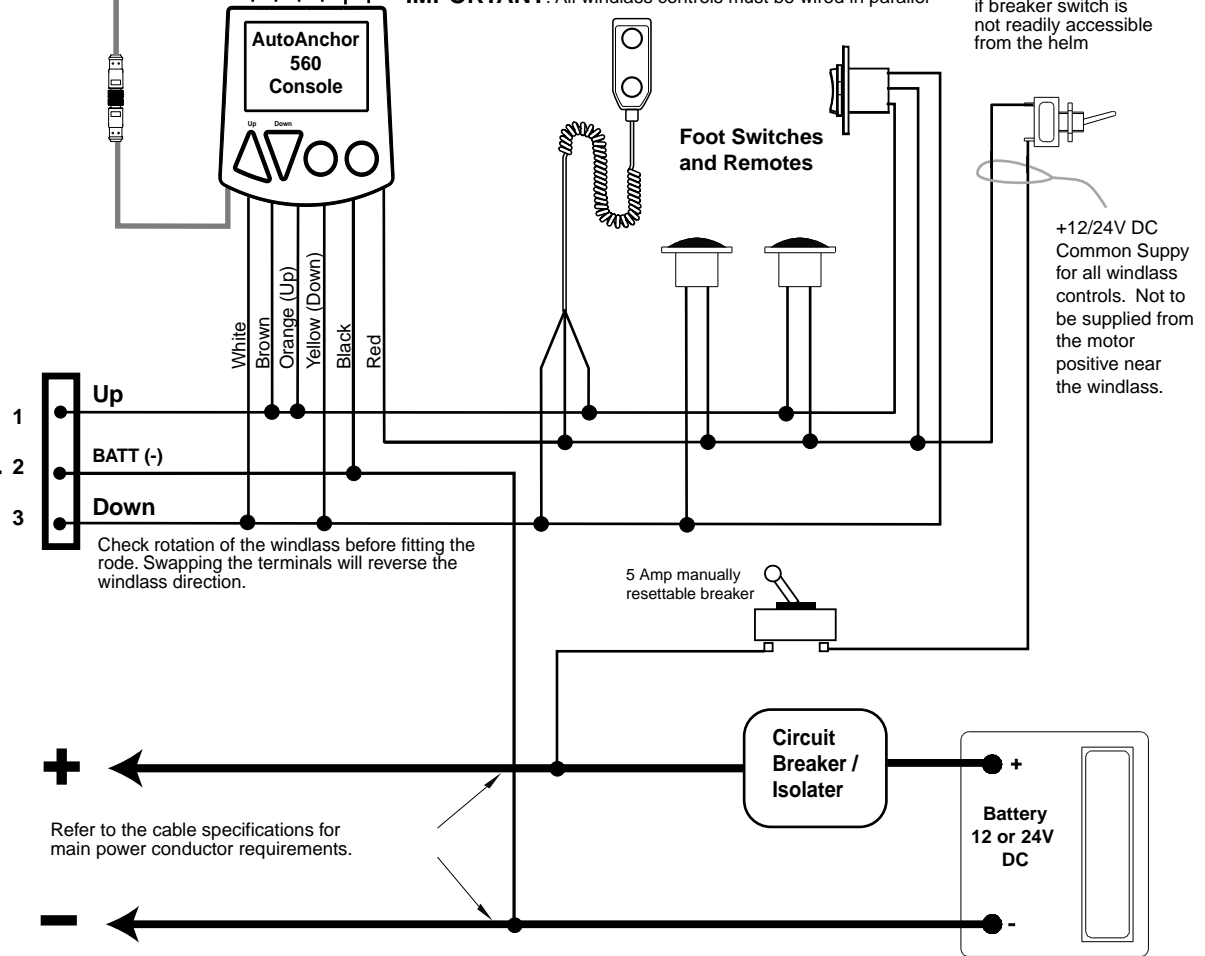
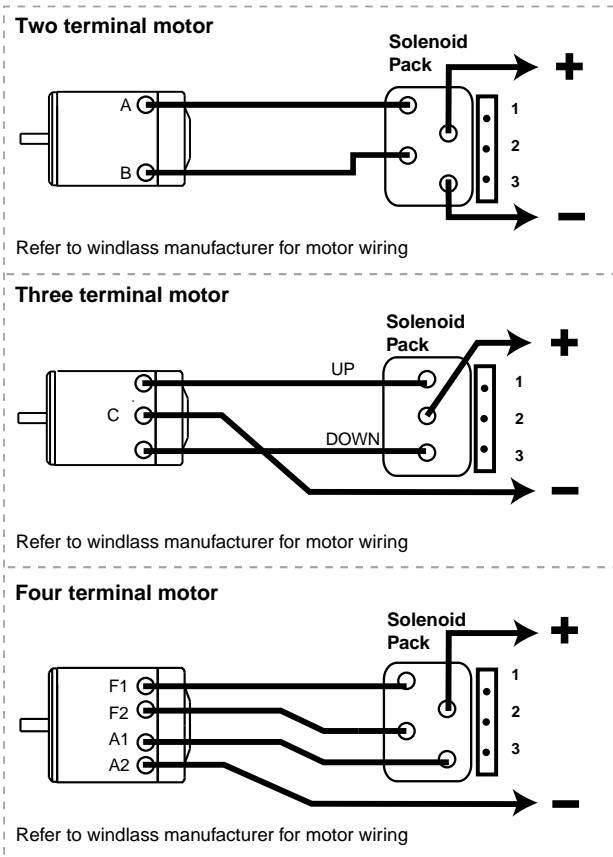

WARNING: Power must be disconnected during installation and when making any changes to wiring after installation

INSTALLATIONS MUST BE CARRIED OUT IN ACCORDANCE WITH USCG, ABYC, NMMA and BMEA REQUIREMENTS